iWarp

A System Architecture for

High Performance

Signal and Image Processing

a presentation by Intel Corp

iWarp in a Nutshell

- **Modular Architecture**
Supports 1-d and 2-d expandable systems
- **1-GFLOP per cu. ft. computation density**
Commercial, air cooled package
- **Performance scalable from 10s to 1,000s of MFLOPS**
- **I/O capacity scalable with computation power**
Meets essential needs of Signal and Image Processing
- **Programmable multipurpose system**
Breaks the “special purpose” limitations of earlier systolic systems
Supports a range of computation models from fine-grain systolic to course-grain message based

Intel Corporation

- **Components**

- Noted for the invention of the DRAM, EPROM
and μ Computer

- Dominant portion of business

- **Boards and Systems**

- 3,000 employees

- 1/3 of 1987 revenues

- **Concurrent Computers**

- Three principal technologies

- \$150M strategic investment

Intel's Concurrent Computing Spectrum

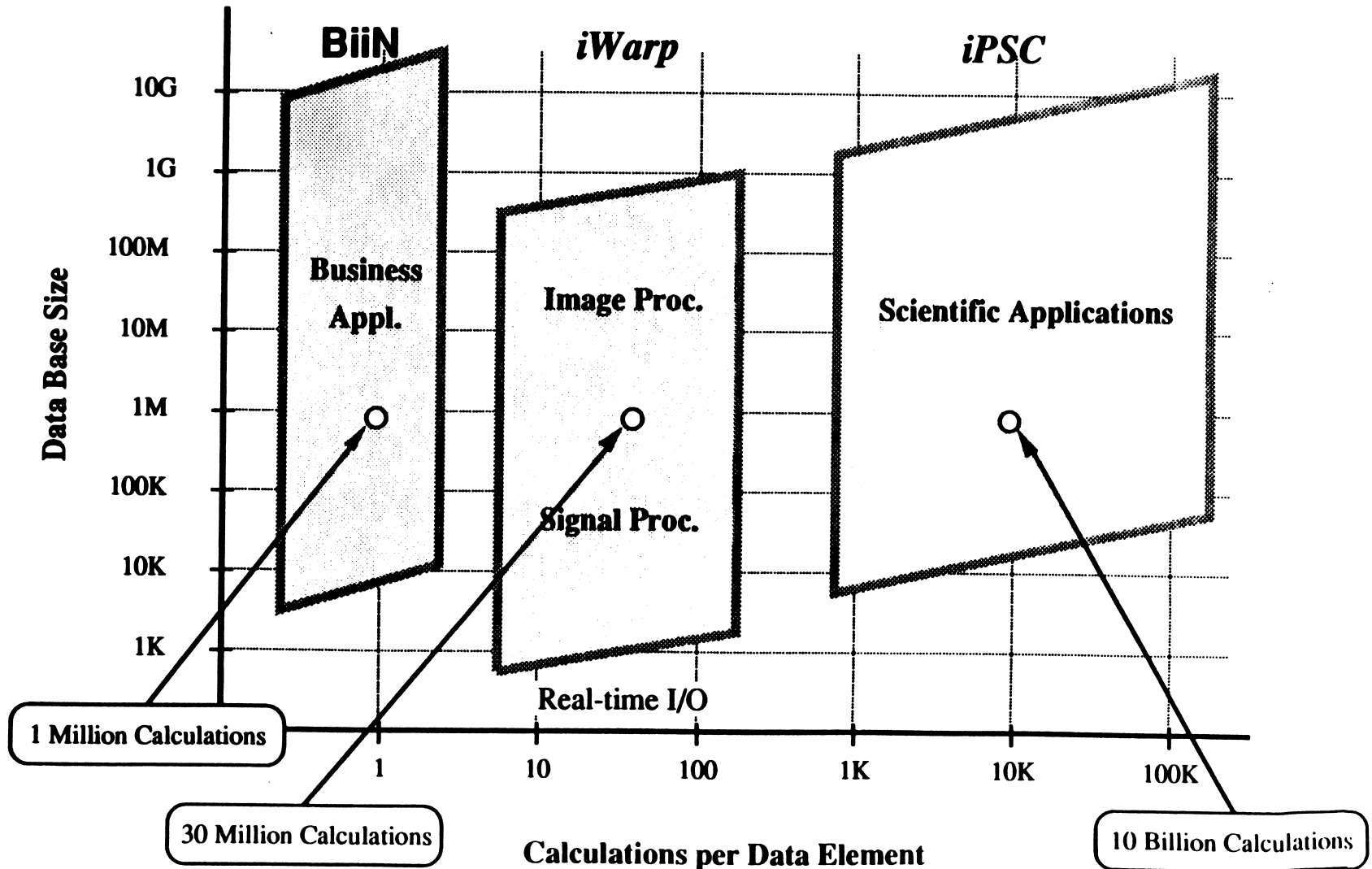

Signal vs. Scientific I/O Requirements

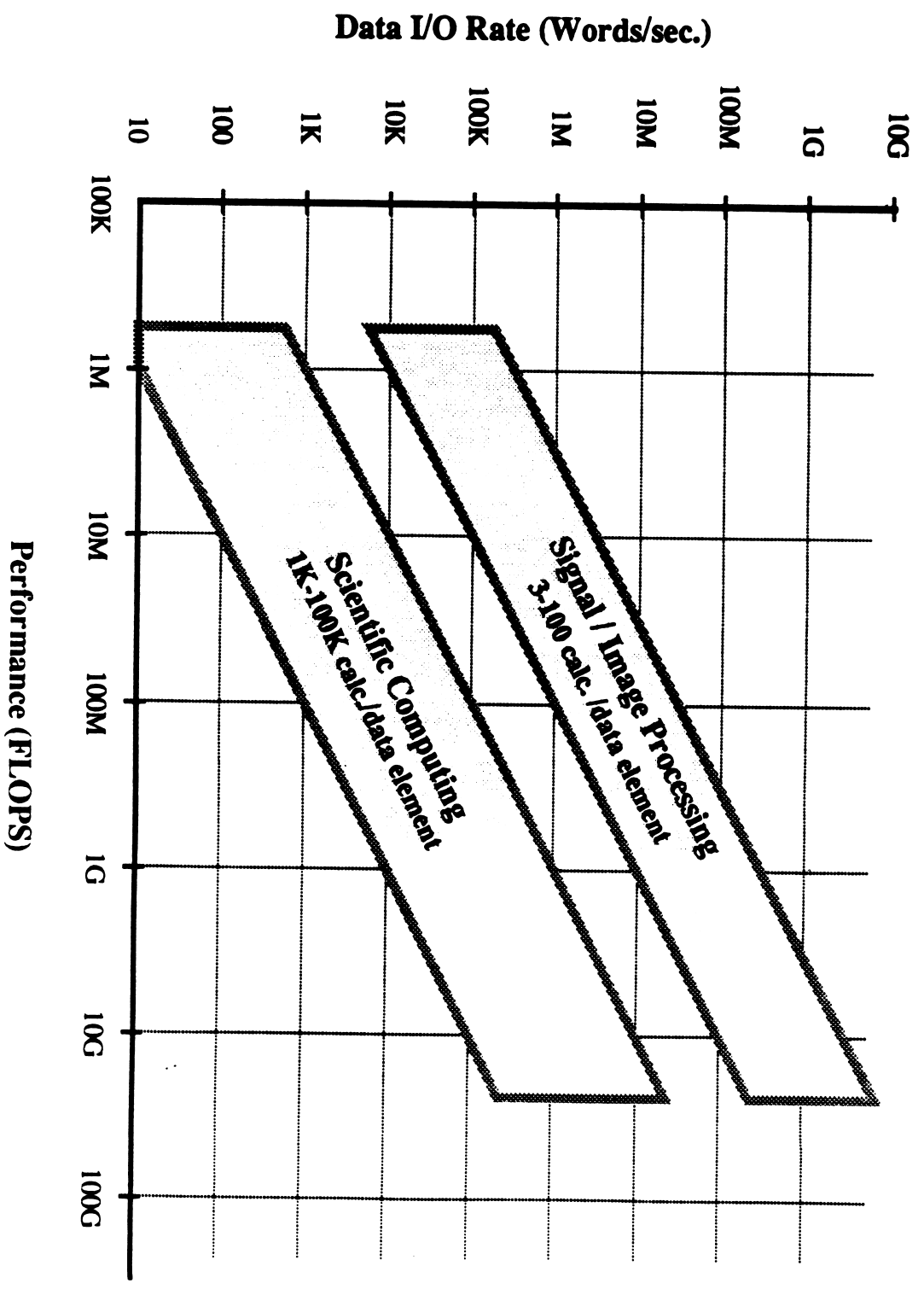

Synergy between Warp and iWarp

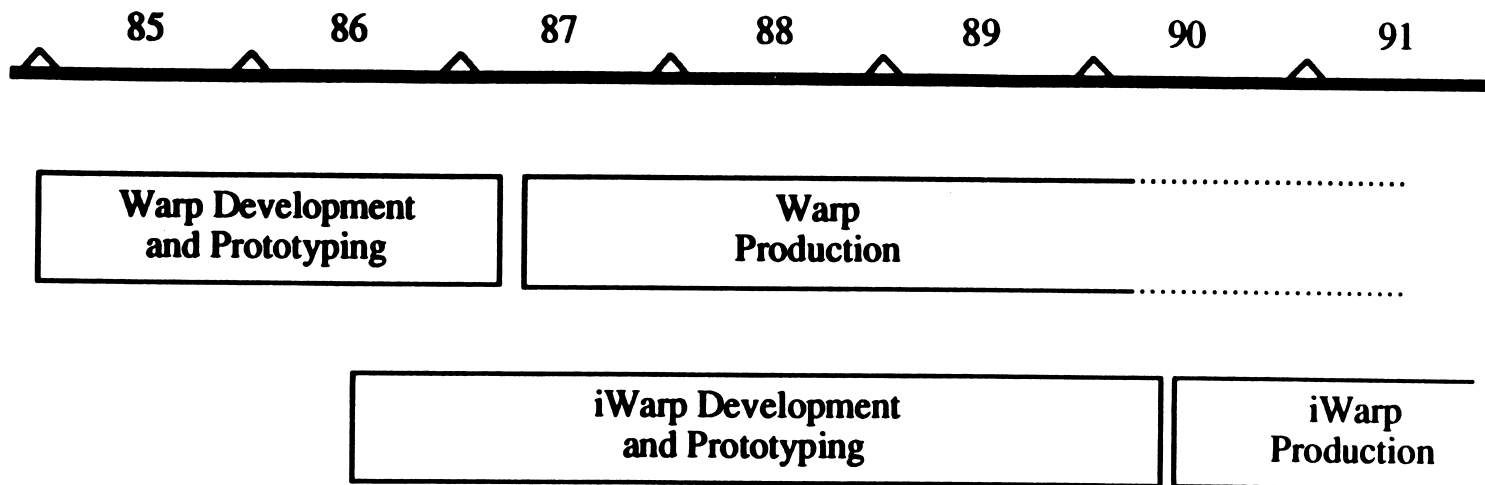

- **Warp compiler and applications are retargetable to iWarp (CMU)**
- **Warp application programs provide experience and performance expectations for iWarp**
- **GE Syracuse is actively promoting the technology**
 - More than 16 Warp systems have been delivered
 - An active users group meets annually

iWarp Cell Architecture Overview

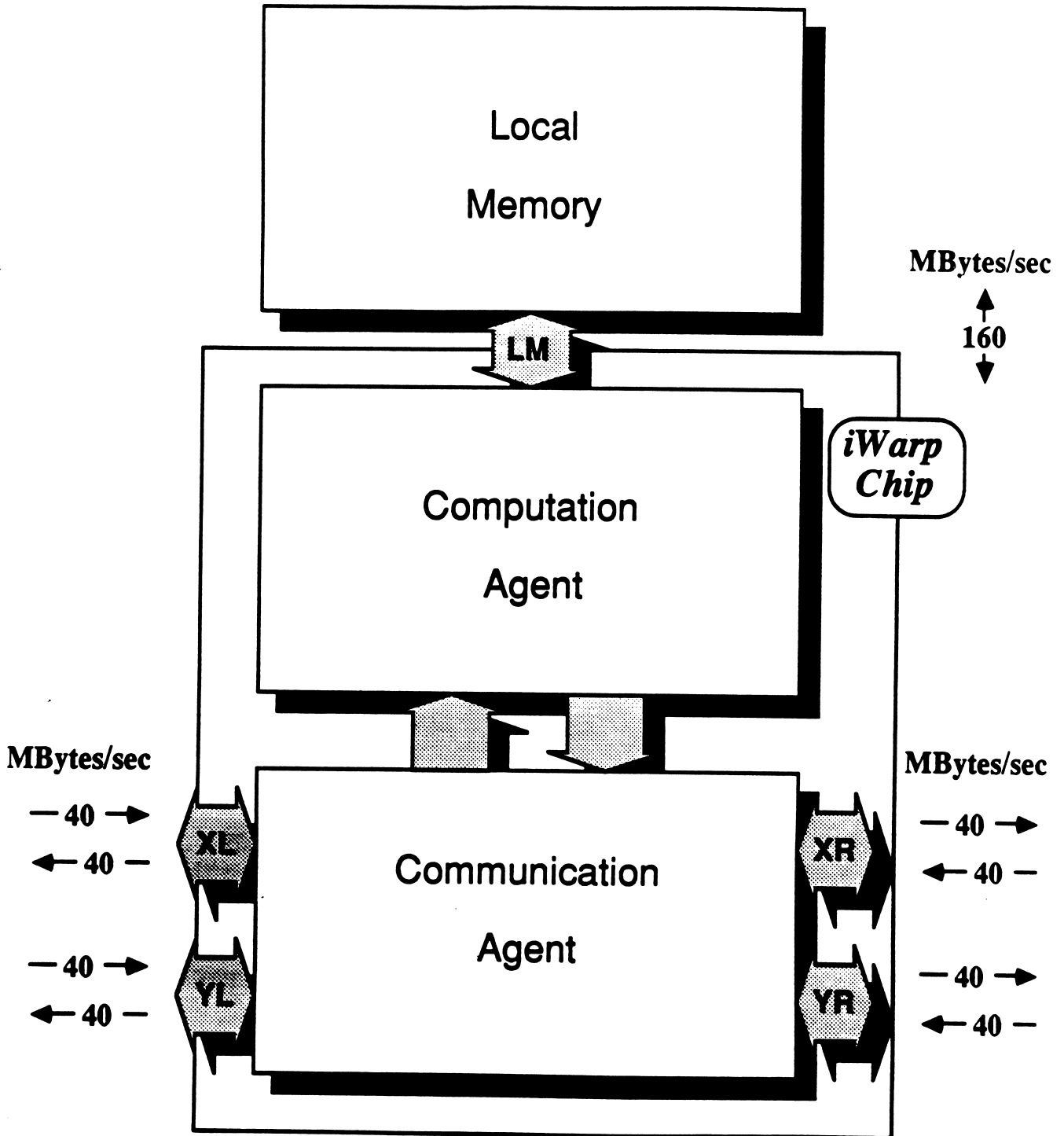

iWarp Systems, Boards and Component

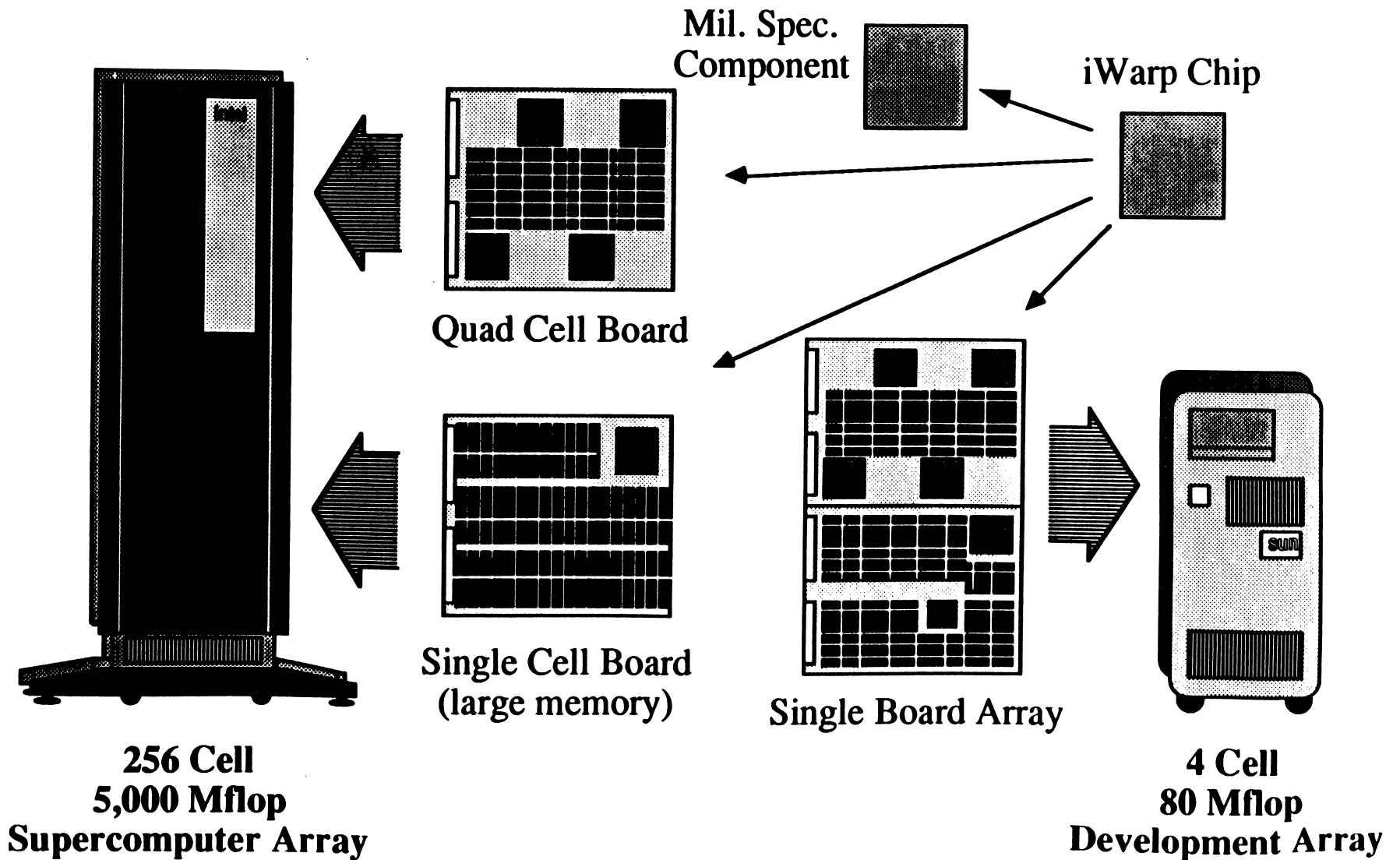

iWarp System Concepts

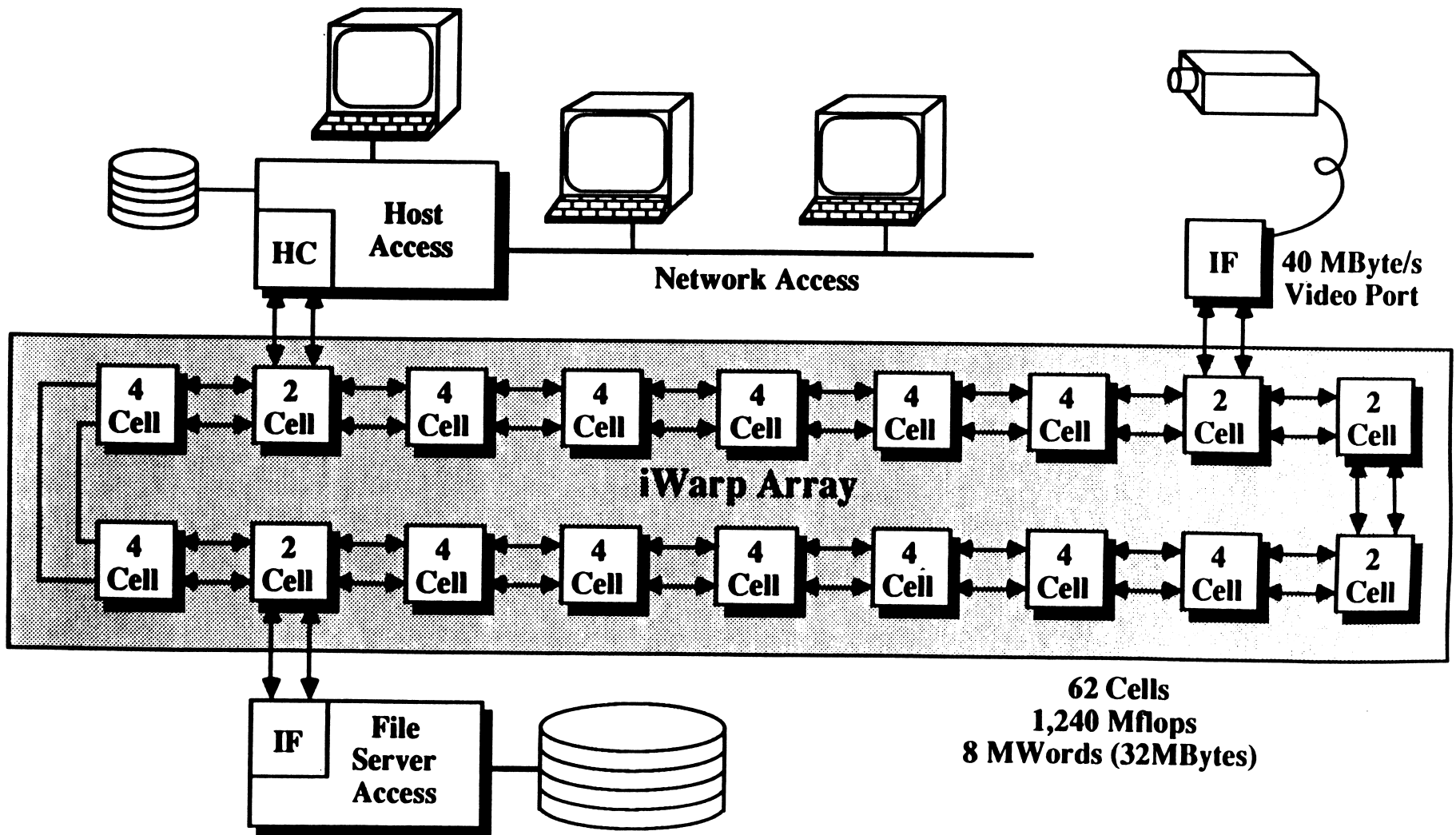

iWarp Usage Models Summary

Tightly Coupled Tasks

- **Pipeline:** 1-d convolution, FFT, relaxation, dynamic programming
- **Local Computation:** Matrix multiplication, 2-d convolution, Hough transform
- **Recursive Computation:** Recursive filtering, solution of triangular linear system, QR-decomp.

Loosely Coupled Tasks

- **Domain Decomposition:** Finite element modeling, Monte Carlo analysis
- **Divide-and-Conquer:** Sorting algorithms, geometric surface analysis
- **Query Processing:** Search
- **Multifunction Pipeline:** Sequence of dependent heterogeneous processes
- **Task Queue:** Master/Slave, heap process